



INTRODUCTION

The V-Notch Ball Valve gives non-clogging, high capacity, straight through flow control of fluids containing pulp and paper stock or slurries and fluids containing suspended solids or fibrous materials.

The V- Notch Ball Valves are offered squared and clamped driven shaft plus ball shaft with splined connection designed for zero lost motion for highly accurate positioning and precise control.

SPECIFICATIONS

DESIGN	: BS. 5351
SIZE	: 25 to 200 mm (1" to 8")
RATING	: ANSI 150
END CONNECTION	: Flanged End
F/F DIMENSIONS	: ANSI B-16.10
FLOW CHARACTERISTICS	: Approx. Equal Percentage, Linear, On-Off.
FLOW DIRECTION	: Forward(into convex face of
MAX. BALL ROTATION	: 90°
BODY MATERIAL	: Carbon Steel, Stainless Steel and Alloy Steel etc.
BALL MATERIAL	: CF8M Chrome plated/Alloy steels.
SEAT RING	: PTFE, Carbon Filled Teflon.
BALL RING	: CF8M, Alloy steels.
GASKET	: PTFE, Graphite Laminate.
GLAND PACKING	: PTFE V Rings, Grafoil.
ACTUATOR FORM	:Diaphragm, Rotary, Cylinder, Electric
ACTUATOR TYPE	: Scotch
DIAPHRAGM	: Nitrile / Neoprene.
SPRING RANGE	: 3 – 15 Psig (0.2 – 1.0 Kg/cm ²) : 6 – 30 Psig (0.4 – 2.0 Kg/cm ²)
AIR SUPPLY	: 20 – 35 Psig (1.4 – 2.5 Kg/cm ²)
AIR CONNECTION	: 1/ 4" or 1/ 2" NPT
ACCESSORIES OPTIONAL	: Valve Positioner – Pneumatic, Electro Pneumatic, Airset, Solenoid Valve, Air Lock, Volume Booster, I/P Converter, Position Transmitter, Limit – Proximity Switches etc.

Top or Side Mounted Handwheel

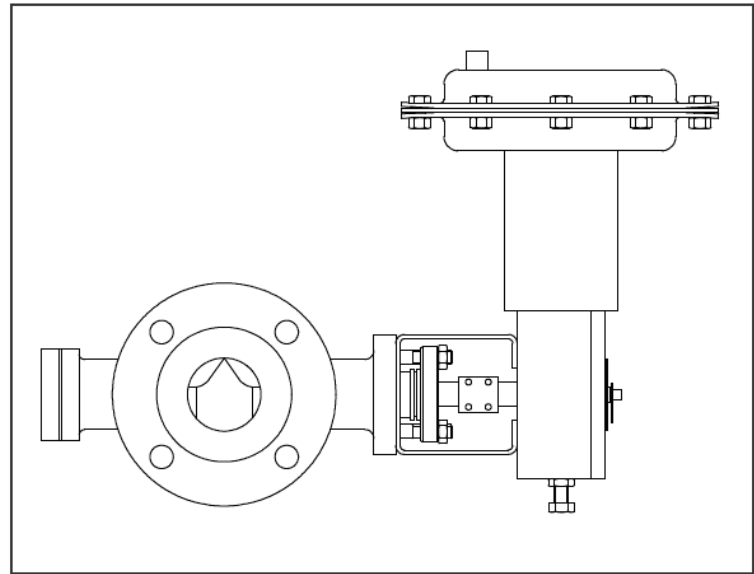

V-NOTCH BALL VALVE WITH ACTUATOR

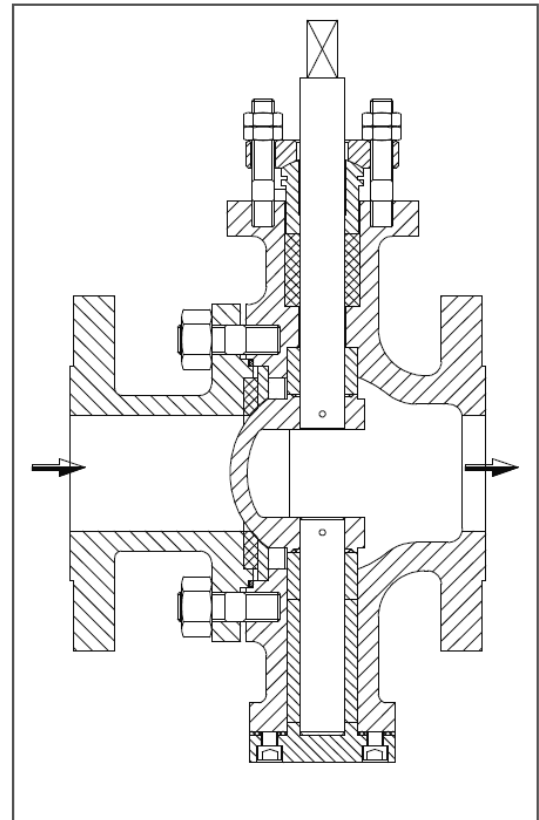

V-NOTCH BALL VALVE

DESIGN FEATURES

- >> A Shearing effect between the ball and seal ensures tight shut-off, even on fibrous slurries.
- >> The unrestricted, straight – through flow design provides high capacity and wide rangeability.
- >> Precise contouring of the V-notch balls provides a nearly equal percentage characteristic.
- >> Replaceable ball seal and back up ring for added rigidity.
- >> Ball machined to a super smooth finish, hard – chrome plated and polished to increase ball seal life.
- >> High Cv to body size ratio.

QUALITY AND PERFORMANCE GUARANTEE

- >> Produced with Quality Systems accredited to ISO 9001 : 2000 (Certificate No. 208920.) by Bureau Veritas.
- >> Full material certification available for all major component Parts.
- >> Full guarantee on design and Performance.
- >> All testing are performed to the requirements of ANSI B16.34.

VALVE SIZING CO-EFFICIENT Cv RATING

VALVE SIZE	Inches	1	1.1/2	2	2.1/2	3	4	6	8
	mm	25	40	50	65	80	100	150	200
Cv (MAX.) AT 90° OPENING		26	78	120	220	325	595	1050	1750

**PRESSURE / TEMPERATURE
FOR PTFE BALL SEALS**

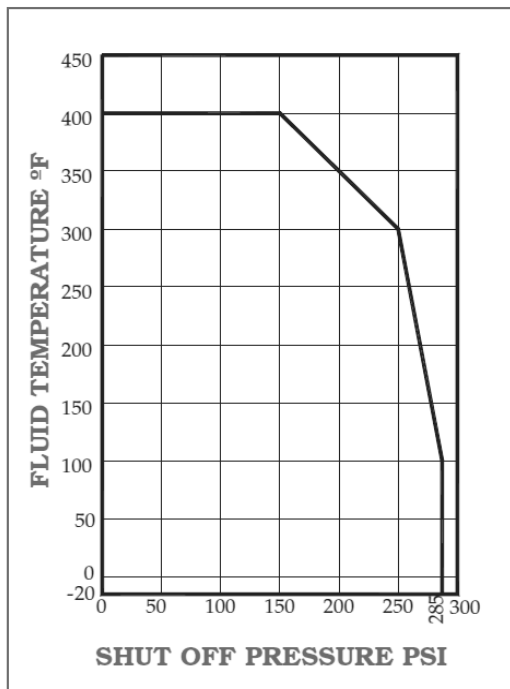

**FLOW CHARACTERISTIC CURVES
90° OF OPENING**

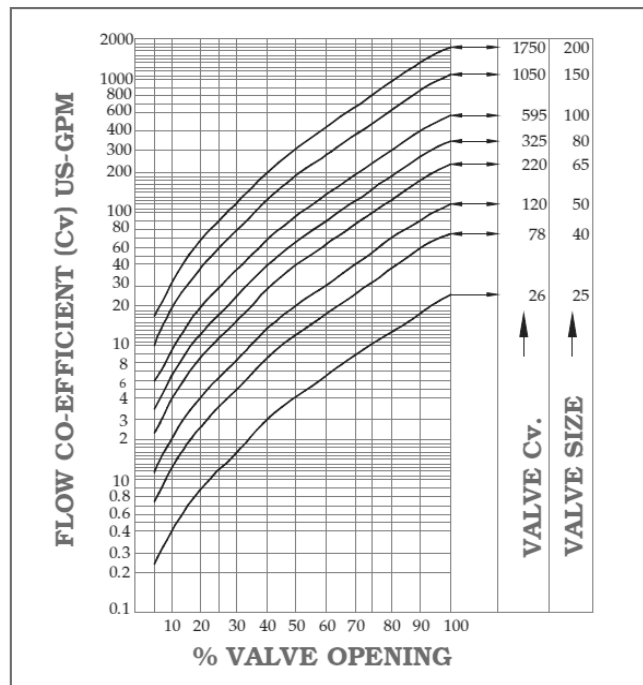

MOUNTING DIMENSIONS FOR V-NOTCH BALL VALVE

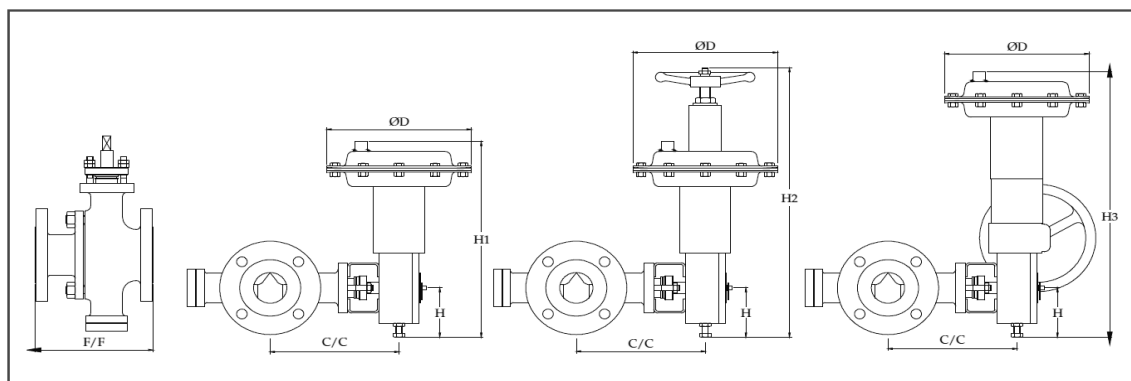

VALVE SIZE	ACTUATOR MODEL	FACE TO FACE		C / C	D	H	STD	TMH	SMH
		ANSI 150	ANSI 300				H1	H2	H3
25	PDS-055-90°	127	165	250	286	125	500	750	775
40	PDS-055-90°	165	190	280	286	125	500	750	775
50	PDS-055-90°	178	216	280	286	125	500	750	775
65	PDS-095-90°	190	241	315	371	125	525	775	800
80	PDS-095-90°	203	283	315	371	125	525	775	800
80	PDS-140-90°	203	283	335	443	150	725	1075	1000
100	PDS-140-90°	229	305	365	443	150	725	1075	1000
150	PDS-140-90°	267	403	415	443	175	825	1225	1150
150	PDS-300-90°	267	403	425	616	225	925	N/A	1300
200	PDS-300-90°	292	419	510	616	225	925	N/A	1300

INSTALLATION

The valve should preferably be installed with actuator vertically above or below the valve body. It can be installed in a horizontal or angled position if actuator is suitably supported. Necessary clearance should be provided above the actuator to permit servicing. The flange bolts are to be tightened evenly to avoid placing strain on the body. The inlet of air pressure regulator (Air set) should be connected to the pneumatic supply line. Supply pressure to the diaphragm actuator should be either 1.5 kg/cm² (20 psig) or 2.5 kg/cm² (35 psig) as per indication on the nameplate. For cylinder actuator, supply pressure specified. For control applications, the air set and valve positioner are mounted, piped and adjusted at the factory.

FINAL CHECK

After installation, check the valve operation for full stroke as indicated on the nameplate, check for leaks in air line connection. Open and close the valve two or three times to ensure proper operation. Before commissioning the process flow, it is essential to flush clean the piping properly. Ball valves require minimum maintenance for its operation. Apply a few drops of oil on the exposed guides and bushings, Hand wheel, if present, must be greased periodically.

ENTECH CONTROLS

Office: 122, Guru Gobind Singh Indl. Estate, Western Express Highway, Goregaon (E),
Mumbai – 400 063, Maharashtra .Tel. – (022) 26854196.

Works: 95 / 7 Road No. - 19, M.I.D.C., Satpur, Nashik – 422 007, Maharashtra

Tel – Fax: (0253) 2360948, Mobile No. 09867390512

Email: – entehnsk@gmail.com, www.entechncontrols.com